

Project	
Notes	
Type	Date
Cat. No.	

SPIR-OSDL/BT-DC200 AleoBlue, Wireless Bluetooth PIR Occ Sensor w/ Daylight Harvesting

DESCRIPTION

The SPIR-OSDL/BT-DC200 combines occupancy sensing, daylight harvesting, 0-10V dimming and Bluetooth® mesh radio circuits into a small package. The result is increased occupant comfort and significant energy savings that meet the most demanding building energy codes. By leveraging Bluetooth® mesh, the first wireless standard for professional lighting applications which ensures unmatched scalability and reliability, the wireless lighting control system can be seamlessly expanded with Bluetooth® mesh-certified products and/or compatible Bluetooth® switches as needed.



APPLICATIONS

Indoor: Open offices, Individual offices, Conference rooms, Classrooms, Retail stores, Hospitals, Lobbies.

SPIR-OSDL/BT-DC200

AleoBlue, Wireless Bluetooth PIR Occ Sensor w/ Daylight Harvesting



Specification Features

Overview

- Bluetooth® mesh compliant
- PIR occupancy detection
- Daylight harvesting
- Task tuning
- Autonomous sensor-based control
- OTA firmware upgrade
- On-board antenna
- Waterproof grade: IP20 (indoor use only)

Certification

UL Listed.

Warranty

5-year Limited Warranty. See warranty documentation for more information.

Benefits

- Cost-effective solution for energy savings
- Energy code compliance
- Robust mesh network
- Decentralized control (no single point of failure)
- Gateway-less configuration & operations

Ordering Information

Example: SPIR-OSDL/BT-DC200

SPIR	OSDL/BT	DC	200
Series	Controls	Input Power	200
SPIR PIR Sensor	OSDL/BT Wireless Bluetooth Occupancy Sensor with Daylight Harvesting	DC Direct Current	Designator with terminal connection

Performance Summary

Input Voltage	12-24VDC
Current Consumption	20mA
Standby Power Consumption	< 0.5W
Factory Reset	Magnetic & Button Reset
Status Indicators	Green (network status), Red (occupancy detection)
Wireless Protocol	Bluetooth® mesh
Wireless Range	82 feet(25m)*
Occupancy Sensing Type	Passive infrared (PIR)

Daylight Harvesting Type	Ambient light sensor/light pipe (closed loop)
Sensing Information	Can be shared within Bluetooth® mesh network
Operating Temperature Range	0°C to 45°C
Operating Humidity	8%-80% (non condensing)
Color	White
Warranty	5 years

*Bluetooth Range is highly dependent on the integration of fixtures, surrounding environment and conditions. It is recommended to conduct testing for range accuracy.

Detection Area

Coverage Side View

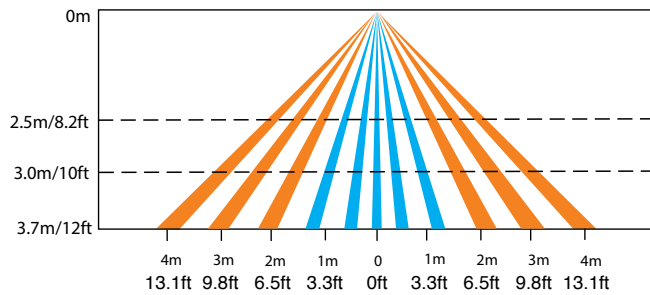

The detection area for movement sensor can be roughly divided into two parts:

- Slow movement (person moving < 10/s or 0.3m/s)
- Quick movement (person moving > 1.3/s or 0.4m/s)

Coverage Top View

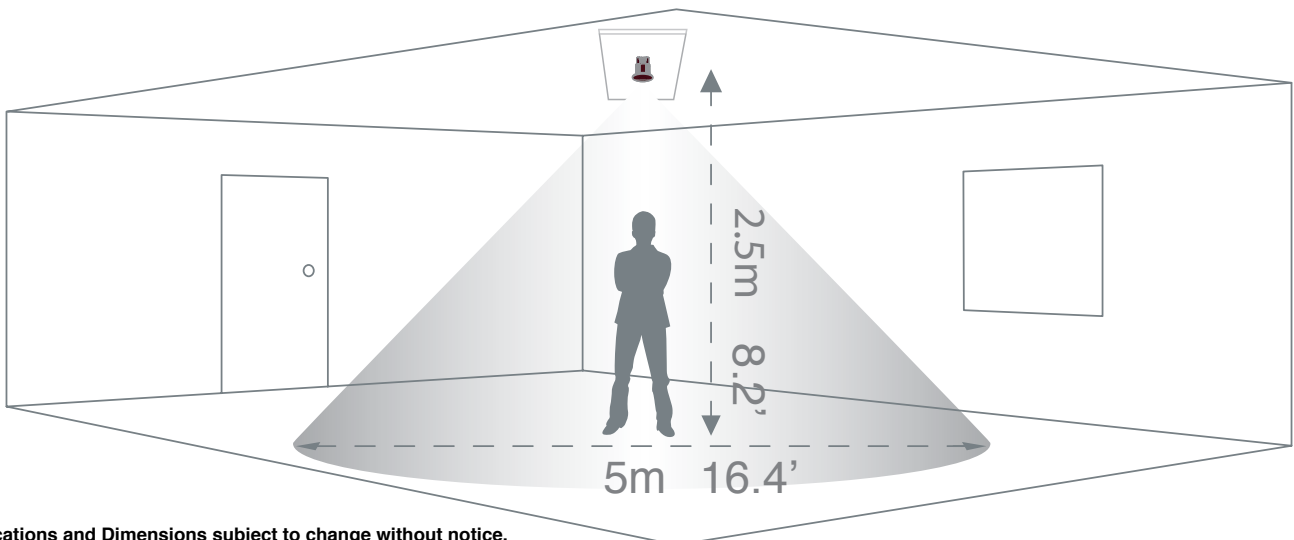
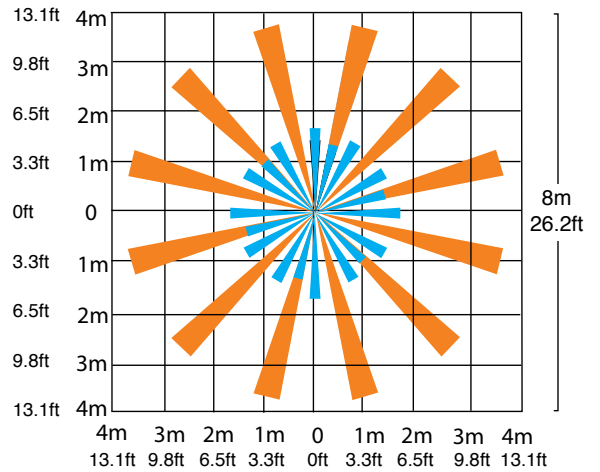

Specifications and Dimensions subject to change without notice.

Wiring Diagram

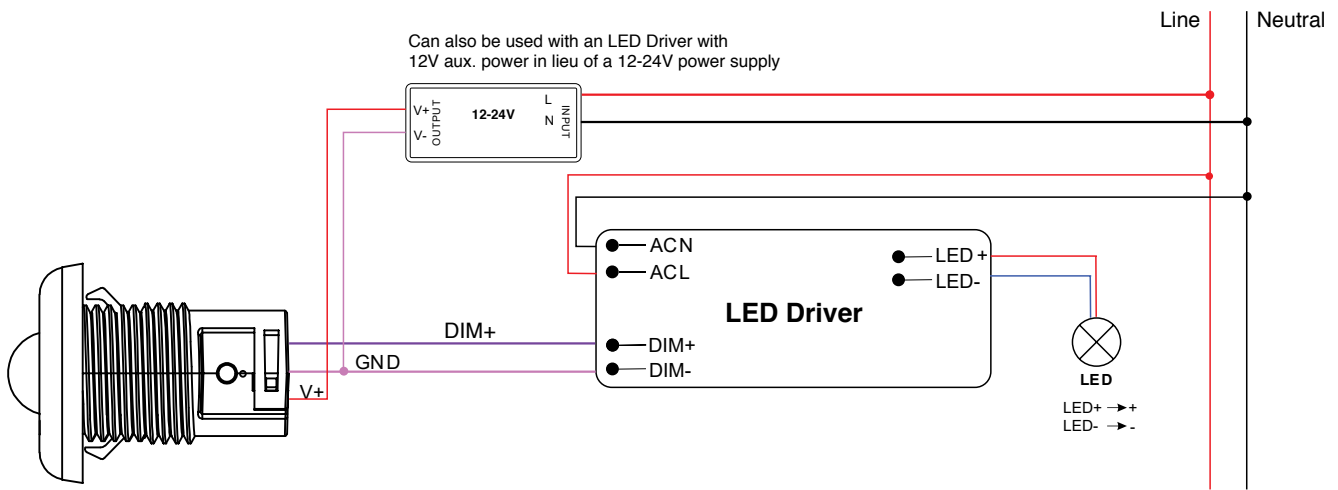

Dimensions

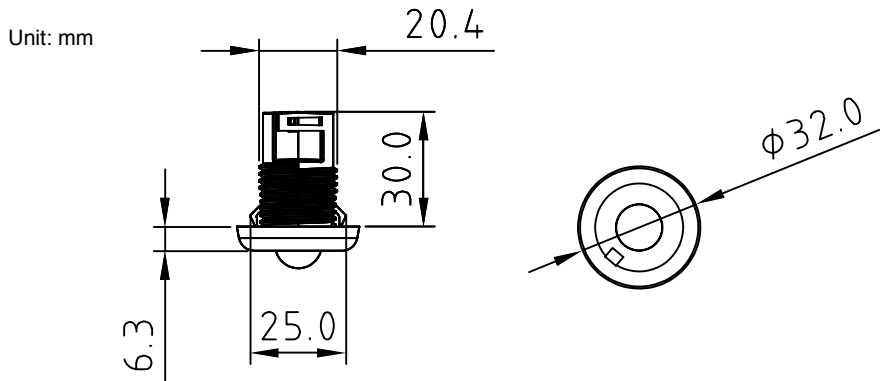

Product Info

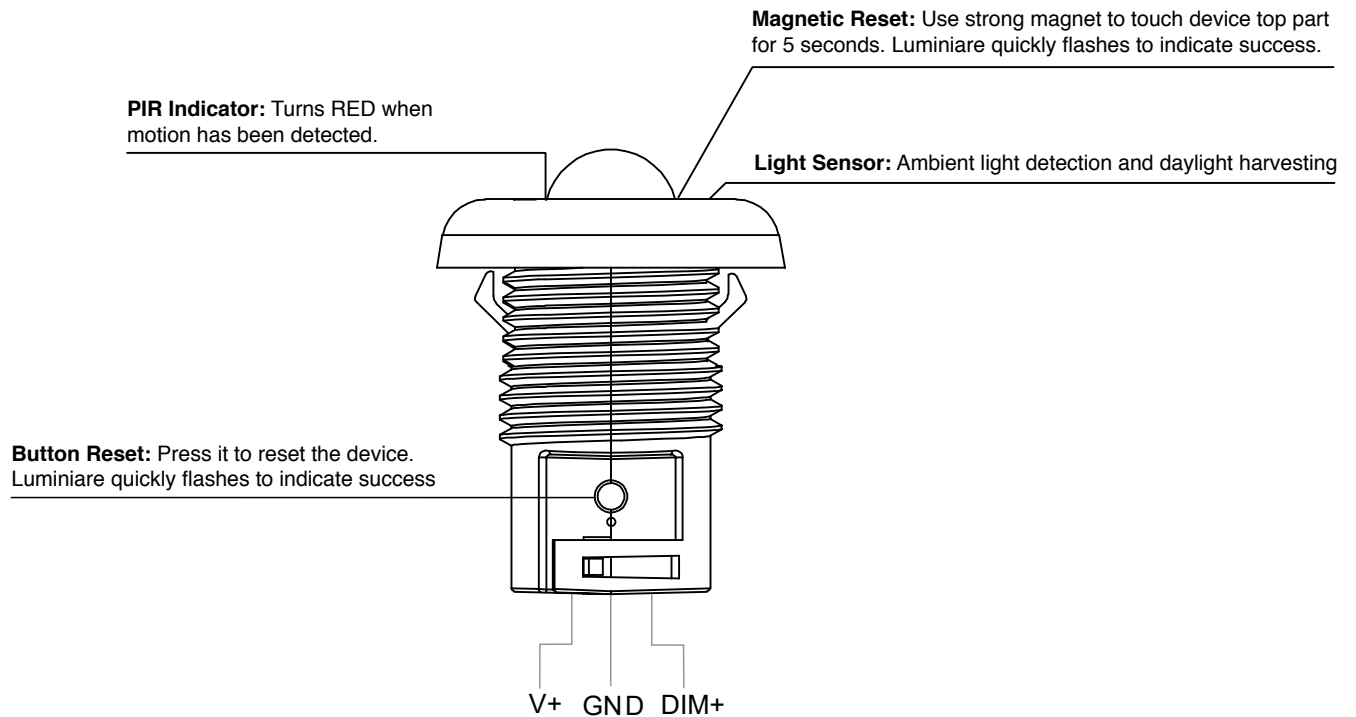

Installation

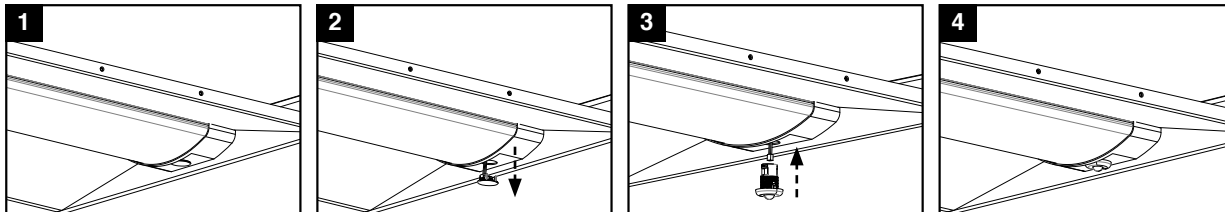

1 Locate the sensor cap.

2 Remove the sensor cap. Sensor wiring harness connector is attached to the cap.

3 Mate the wiring harness connector with the connector on the sensor and push, ensure solid connection. Push and lock the sensor into the fixture hole.

4 Secure the sensor. If necessary, use lock nut.



AleoBlue Wireless Bluetooth Controls



The AleoBlue is a complete solution for managing connected lighting systems using a Bluetooth Mesh lighting network. This enables seamless implementation of simple to complex lighting control scenarios without specialized training or lighting control engineering expertise.

DLC NLC Qualified.

Features and Benefits

- Lighting Zones / Grouping
- Manual control of individual lights
- On Power up Behavior
- Zone Linking
- Vacancy Sensing
- Per fixture Daylight Control
- Per zone Daylight Control

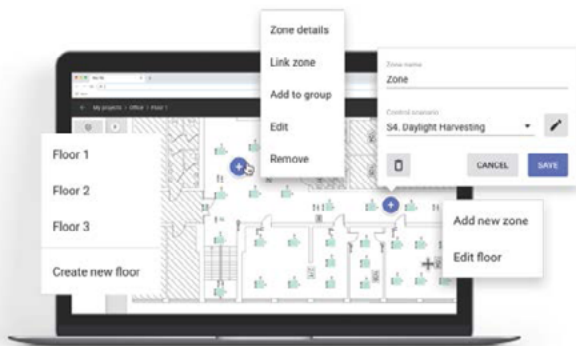

- Optimized Energy Consumption
- Less Hassle with On-Site Adjustments
- More Savings
- Increased Safety
- More Flexibility

Scheduling

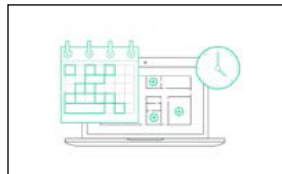

High and Low End Trim

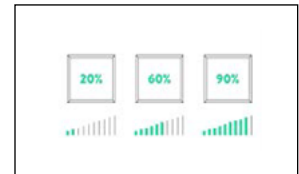

Scenes

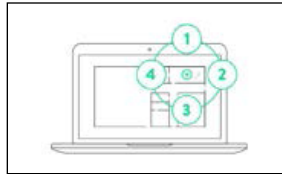

Occupancy Sensing

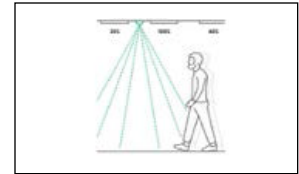

- Intuitive and user-friendly web and iOS apps
- No specialized training or lighting control expertise required
- Optimized for commercial spaces of any size
- No additional wiring or central control box
- Customizable lighting control parameters
- Future proof with Software Updates
- Multiple Zone Configurable
- Built-In Scenarios + Customization

Bluetooth Mesh Technology Advantages



The fastest low-power communication



Scalability to thousands of devices



The most advanced encryption standards as well as the cutting-edge device authentication



No single point of failure (no central device)



Compatibility with a widely available devices (smart phones & tablets – both with Bluetooth 4.0 and Bluetooth 5)

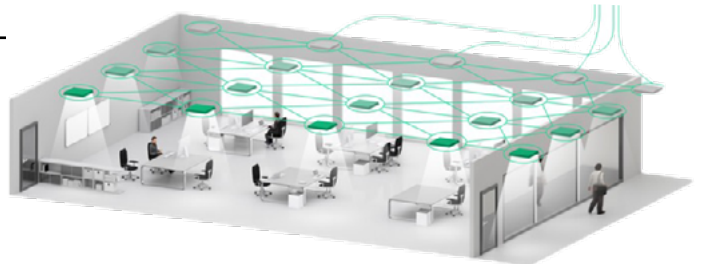

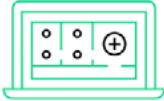

Planning

Remote preparation of a retrofit project with the use of our web app. Uploading floor plans, defining individual lighting zones and choosing lighting control scenarios.

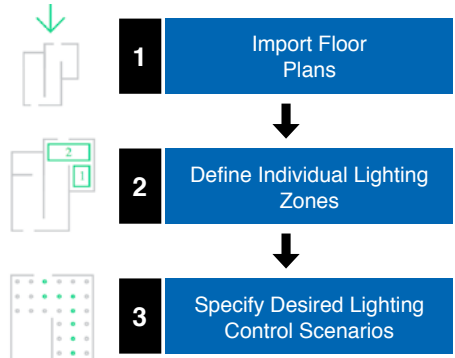

Implementation

Adding lighting devices to the Bluetooth mesh network on-site with the use of an iOS app.

Customization and calibration of lighting control parameters during and after the commissioning process. Defining scenes for specific working activities.

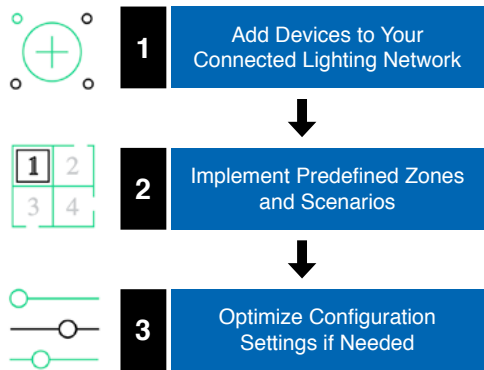

Provisioning / Configurations

The Bluetooth mesh Node is in the Unprovisioned Mode until it is provisioned by a "Provisioner", which typically is a smart phone with a Bluetooth mesh compatible app.

Ordering Information



AleoBlue, Wireless Bluetooth PIR Occ Sensor w/ Daylight Harvesting
Model: SPIR-OSDL/BT-DC200

Specifications and Dimensions subject to change without notice.

Lighting Control Scenarios

Multiple lighting control scenarios are available once the Bluetooth mesh Node is provisioned. At each scenario, duration, fade time and target brightness can be configured at any time with the iOS app.



Mode / Scenario	Wireless Switch	Occupancy Sensor	Ambient Light Sensor
Unprovisioned Mode	-	-	-
Switch	On / Off / Scenes	-	-
Occupancy	On / Off / Scenes	Auto On / Off	-
Vacancy	On / Off / Scenes	Auto Off	-
Occupancy with Daylight Harvesting	On / Off / Scenes	Auto On / Off	Enabled
Vacancy with Daylight Harvesting	On / Off / Scenes	Auto Off	Enabled

Occupancy Scenario

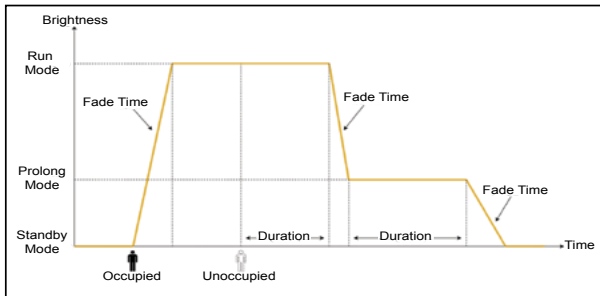

Vacancy Scenario

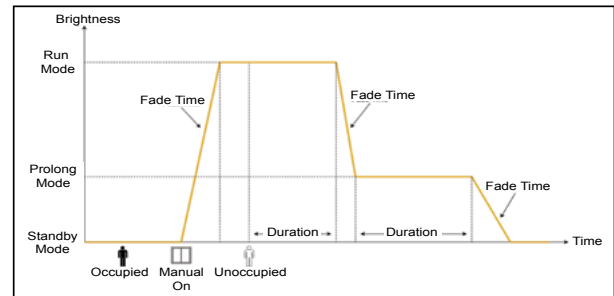

Occupancy Scenario - with Daylight Harvesting

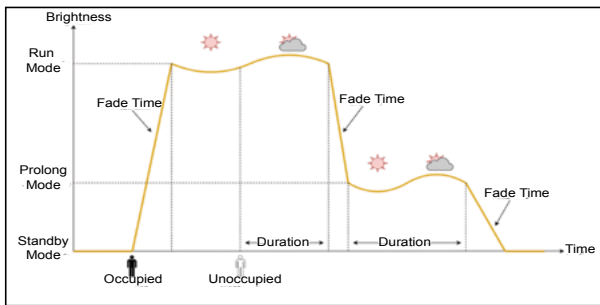

Occupancy Scenario with Manual Override

